

Fig. 1

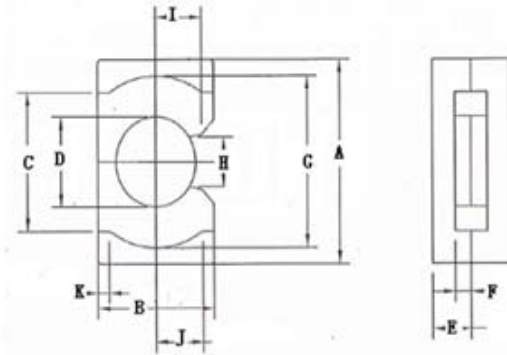

Fig. 2

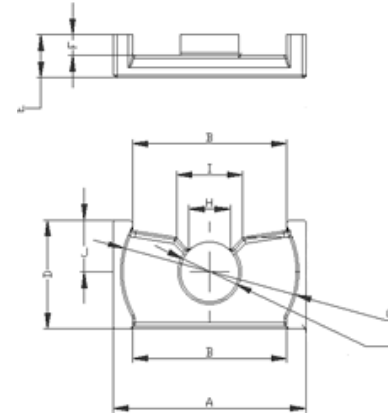

Fig. 3

EQ型

尺寸Dim 型号 Type	图形 Fig.	A (mm)	B (mm)	C (mm)	D (mm)	E (mm)	F (mm)	G (mm)	H (mm)	I (mm)	J (mm)	K (mm)	G_1 (mm^{-1})	Le (mm)	Ae (mm^2)	Ve (mm^3)
EQ18	1	13.0 ± 0.2	18 ± 0.25	7.2 ± 0.1	16.2 ± 0.25	6.6 ± 0.1	7.5 ± 0.2	4.7 ± 0.2	$13.8 + 0.4$ $/-0.15$	—	—	—	0.90	19.43	21.20	418.20
EQ25/13.7	3	25.0 ± 0.4	20 ± 0.4	7.6 ± 0.2	13.7 ± 0.4	5.42 ± 0.1	2.62 ± 0.15	23 ± 0.4	5.43ref	8.6ref	6.5 ± 0.2	—	0.69	31.25	45.34	1416.88
EQ25/14.7	3	25.0 ± 0.4	17.4 ± 0.4	17.9 ± 0.4	14.7 ± 0.4	4.8 ± 0.1	2.0 ± 0.15	21.4 ± 0.4	6.1MIN	8.5ref	6.5 ± 0.2	—	0.55	35.47	64.50	2302.00
EQ25/16	2	25.0 ± 0.4	16.0 ± 0.4	17.0 ± 0.4	11.0 ± 0.2	4.9 ± 0.15	1.9 ± 0.15	21.0 ± 0.4	6.0 MIN	6.3 ± 0.2	6.5 ± 0.2	1.5 ± 0.2	0.30	29.00	96.00	2784.00